



FORD TRUCK EQUIPMENT



TS/ISO Registered



ADRIAN STEEL®

Cargo Management Solutions for Commercial Vehicles



PLAN YOUR VAN

IF YOU ARE LOOKING FOR EQUIPMENT TO ORGANIZE YOUR CARGO VAN, YOU HAVE COME TO THE RIGHT PLACE.

Adrian Steel has all the storage products you will need, and the tools to put them all together to best utilize the space in your vehicle. This catalog is set up to walk you through the product categories as you would add them into your vehicle. Follow these simple steps to create an interior that fits your needs:

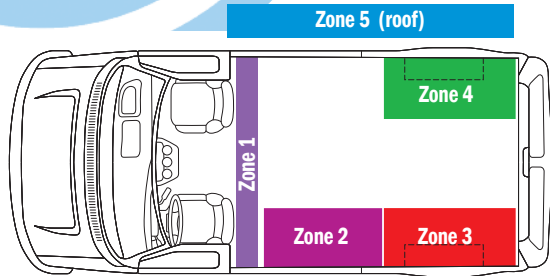

Zone 1 Partition

- Choose partition style.
- Choose the standard or 3" setback wing kit for the Econoline.
- Add accessories on both cab and cargo sides.
- **I need:**

Zones 2, 3, 4 Curbside & Streetside

- Use layout diagrams to determine the amount of space available.
- Choose from a variety of shelving units and modules that will best organize the tools and equipment you need to carry.
- **I need:**

Zone 5 Roof

- Determine what will be carried: ladders, sheet goods, conduit, etc.
- Choose from LoadsRite, Grip-Lock, Utility and Cargo racks.
- Add rack accessories including step ladder kits, ratchet straps, conduit carriers and more.
- **I need:**

Additional Storage

- Determine the space needed for specialty equipment: tank racks, lockers, reel holders, Stow-Alls and more.
- Add accessories including door kits, drawer units, hooks and more.
- **I need:**

Ford Full-Size Van 1996-on

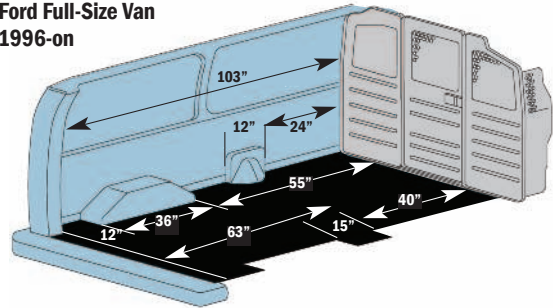

Ford Extended Van 1996-on

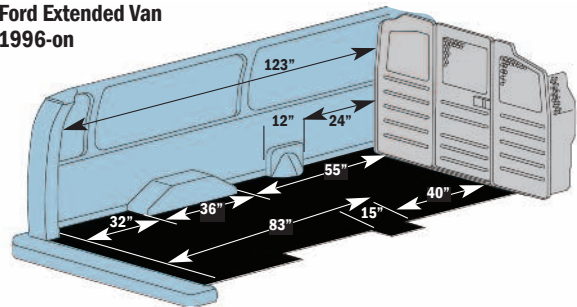

Get Cash Back from Ford On Adrian Van Upfits and Pickup Equipment.

Qualified commercial customers can receive a reimbursement from Ford on Adrian Steel upfits with the purchase or lease of new E-Series cargo vans through the Ford Truck Commercial Connection Program.

Get the van equipment you want and quick. Before you take delivery of your new Ford van contact your local Adrian Steel distributor to select the equipment or package that fits your exact needs.

Bring in the equipment quote or invoice to your Ford dealer. The dealer will process your available reimbursement through the Ford Truck Commercial Connection Program. If needed, the dealer will arrange the upfitting of the equipment and you'll be ready to go. See your local Ford dealer for program qualifications and eligibility.

For more information about the Ford Truck Commercial Connection Program and the name of your local Adrian Steel distributor call 1-800-677-2726.

BASEPLUS ADSERIES SHELVING



AD
series

For the Way You Work!

BasePLUS

Not sure what you need in your Econoline? Just start with Adrian Steel's BasePlus package featuring the new ADseries

shelving and add the accessories you need, when you need them! Not only can the ADseries shelving be moved forward and aft in the van without re-drilling, the shelves can be adjusted up and down to accommodate drawer units, door kits, plastic bins and more. For the ultimate in versatility, choose Adrian Steel's BasePlus and ADseries equipment!

Base Commercial Package Full-Size Ford Vans

4456F for long wheelbase Econolines
4456FX for x-long wheelbase Econolines

Item	Model	Description	Qty
1	AD44FP	ADseries 44" shelf unit	3
2	RKFSVFD	ADseries Rail Kit-Ford*	1
3	S1M2HC2FSV	Partition and Wing Kit	1

*use RKFSVXLF for x-long wheelbase vans



ADRIAN STEEL

800.677.2726

ADSERIES SHELVING

Adjustable shelves

Tools, equipment and cargo come in all shapes and sizes and until now, there hasn't been a shelving unit that is truly adjustable. The ADseries is the first of its kind where, with only a screwdriver, you can simply remove the front shelf bolts and move the shelf where you need it. Shelves can be adjusted in one inch increments and provide the most flexible shelving solution available. The ADseries is 46" high by 14" deep and comes in lengths of 32", 44" and 50" wide.

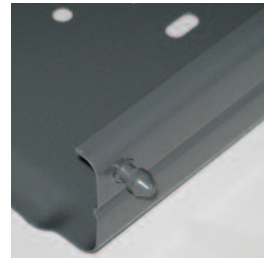
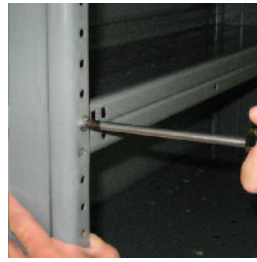
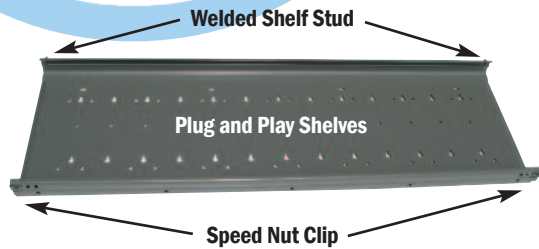

Truly Adjustable Shelves All you need is a phillips screwdriver! Simply remove two bolts from the speed nut clips that come with the shelf, tilt the shelf upwards, move the shelf to your desired location, insert the rear shelf studs, reattach the bolts and you're done!

Rear Shelf Studs unique design lock shelves in place!

ADaptable interior

Everyone likes to set their work van up their own way. The new ADseries shelving lets you position the shelving where you need it. Exclusive to the ADseries, the unique rail system enables you to reposition the shelving in the van, increasing the available space for trade specific equipment. All of this is done without removing bolts, plugging holes and redrilling the van!



Add accessories

Businesses change over time and your van interior should be able to change with your needs. Plug and Play shelves have prepunched holes that allow adding storage solutions easily! ADseries dividers simply snap in place, drawer units simply bolt in and door kits can be added to lock your more valuable parts and equipment. Many Adrian Steel accessories can be added to the ADseries shelving with the rail adapter kits and end panel brackets.



ADseries Shelf Units and Rail Kits

Model	Size/Description
AD32FP	14"D x 32"W x 46"H
AD44FP	14"D x 44"W x 46"H
AD50FP	14"D x 50"W x 46"H
RKFSVFD	Rail System Ford LWB
RKFSVXLFD	Rail System Ford XLWB
RKTC	Rail System Transit Connect

Note: Rails are not included with the shelf units. Rail kits must be ordered separately

Note: Shelves have the following weight rating:
Shelves positioned with the shelf lips facing up have a rating of 100lbs per shelf evenly distributed.
Shelves positioned with the shelf lips facing down have a rating of 200lbs per shelf evenly distributed.

ADseries Accessories

Model	Size/Description
DV14C1	Divider for ADseries/Single
DV14C8	Divider for ADseries/8 Pack
DK3008	8" High Door Kit Door Kit/AD32FP
DK3010	10" High Door Kit Door Kit/AD32FP
DK4208	8" High Door Kit Door Kit/AD44FP
DK4210	10" High Door Kit Door Kit/AD44FP
DK4808	8" High Door Kit Door Kit/AD50FP
DK4810	10" High Door Kit Door Kit/AD50FP
BRK14EPS	End Panel Bracket To Add on Accessories
RKA1	Rail Kit Adapter/See list at right
RKA3	Rail Kit Adapter3/See list at right
RKA4	Rail Kit Adapter4/See list at right
RKABRK1	Rail Kit Adapter/End Panel Bracket/See list
RKABRK2	Rail Kit Adapter/17A
RKAWTR	Rail Kit Adapter/Welded Tank Racks
RKA919	Rail Kit Adapter/#9, #19, #919 Drawer Units
35325-G	32" Long Shelf
35327-G	44" Long Shelf
35328-G	50" Long Shelf

RKA1 - Rail Adapter Kit1
Use with: CB2, CB3, CB4 (uses 2)

RKA3 - Rail Adapter Kit3
Use with: #1, #12, #2, #8, DC Units, 17A, CRH2, TA19, TA5

RKA4 - Rail Adapter Kit4
Use with: CL1446D/R, #40, KDRH2, KD Shelving Units, #33, #3, #33W, JD Shelving

BRK14EPS - ADseries end panel accessory attachment bracket.
Use with: 17A, CB5, 43, TA19, TA20, WRH5, UH10/25/50, PA9, PA8, ACT3/4, PA11, AGSCH2, PA7, TH30, TH50, TA5

RKABRK1 - Used with TA19, TA20, TA5

BASEPLUS PACKAGES FOR E-SERIES

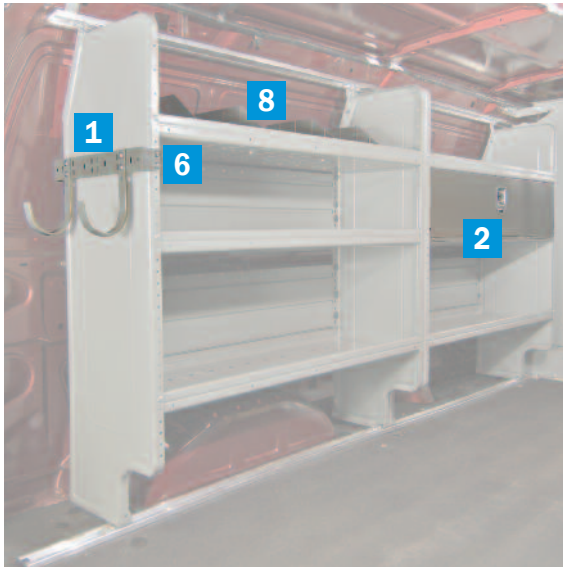

BasePlus

General Service Package

Full-Size Ford Vans

4317F for long wheelbase Econolines
4317FX for x-long wheelbase Econolines

Item	Model	Description	Qty
Base Commercial Package PLUS			
1	UH50	Utility Hook	2
2	DK4208	8" Door Kit	2
3	TA1	Hook Bar	1
4	19	Two Drawer Medium	1
5	DC6	Drawer Component - 6"	1
6	BRK14EPS	End Panel Bracket	2
7	919	Three Drawer Combo	1
8	DV14C8	Divider 8 Pack	1



BasePlus

Plumbing, Heating & A/C Repair Package

Full-Size Ford Vans

4318F for long wheelbase Econolines
4318FX for x-long wheelbase Econolines

Item	Model	Description	Qty
Base Commercial Package PLUS			
1	WTR230150	Welded Tank Rack	1
2	19	Two Drawer Medium	2
3	DC6	Drawer Component - 6"	3
4	DC12	Drawer Component - 12"	1
5	DK4208	8" Door Kit	2
6	TA1	Hook Bar	1
7	VMA36	Vice Mount Assembly	1
8	BRK14EPS	End Panel Bracket	1
9	RKAWTR	Tank Holder Adapter	1
10	919	Three Drawer Combo	1
11	DV14C8	Divider 8 Pack	1

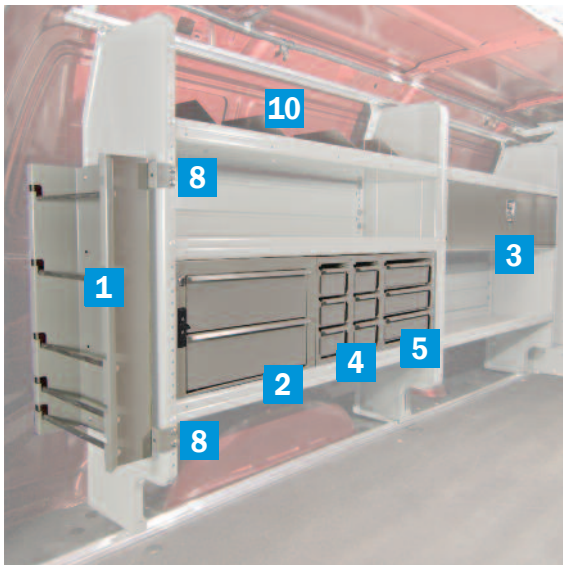

BasePlus

Electrical & Gas Appliance Repair Package

Full-Size Ford Vans

4319F for long wheelbase Econolines
4319FX for x-long wheelbase Econolines

Item	Model	Description	Qty
Base Commercial Package PLUS			
1	WRH5	Wire Reel Holder	1
2	19	Two Drawer Medium	1
3	DK4208	8" Door Kit	2
4	DC6	Drawer Component - 6"	3
5	DC12	Drawer Component - 12"	1
6	9	Four Drawer Shallow	1
7	TA1	Hook Bar	1
8	BRK14EPS	End Panel Bracket	3
9	919	Three Drawer Combo	1
10	DV14C8	Divider 8 Pack	1

ACCESSORIES



Tote Trays and Cases

Measures 19-3/4"W x 20-1/8"H x 13-3/8"L.

Model	Description
SPT-4	Combo Totes and Rack Steel Trays (2) Poly Cases (2)
SPT-4P	Poly Totes and Rack Poly Cases (4)
SPT-4S	Steel Totes and Rack Steel Trays (4)



Drawer Units –Lock 'n Latch System
18"W x 12"H x 12"L steel cabinet with composite drawers. Key locking.

Model	Desc. & Drawer Size (Qty.)
19	2 Drawer Medium 16" W x 5" D x 11-1/2" L (2)
919	3 Drawer Combo 16" W x 2-1/2" D x 11-1/2" L (2) 16" W x 5" D x 11-1/2" L (1)
9	4 Drawer Shallow 16" W x 2-1/2" D x 11-1/2" L (4)



Drawer Components

High-impact polymer construction with drawer retention stops.

Model	Desc. & Cabinet Size
DC6	Base 3 drawer narrow model 6"W x 12"H x 12"D
DC12	Base 3 drawer wide model 12"W x 12"H x 12"D



Cabinet Lockers

Lockers feature a 46" high storage space with removable shelves.

Model	Description & Cabinet Size
CL1446R	Cabinet Locker Full Door 18"W x 46"H x 14"D
CL1446D	Cabinet Locker Short Door 18"W x 46"H x 14"D

PARTITION ACCESSORIES



Wing Extension Kits

Extend the amount of cab space in your E-Series van by an additional 3" with Adrian Steel's extended partition wing kits. This one piece kit is available for those who would like more leg room.



Vehicle Safety

PA7 Triangle Reflector Kit with a metal pocket holder, I.C.C. approved.

PA8 1-A: 10-BC Fire Extinguisher is a rechargeable, 2-1/2 lb. dry chemical extinguisher. Stops Class A, B and C fires. Complete with charge gauge and mounting bracket.

PA9 First Aid Box Tray secures first aid box to partition or other vertical surface.

Overall size: 9"W, 3-1/2"H, 3"D.



Tank Holders

TH30 Refrigerant Tank Holder 30 lb.–holds tank to partition or other vertical surface.

TH50 Refrigerant Tank Holder 50 lb.–holds tank to partition or other vertical surface.

PA10 Practice Holder is a partition-mounted holder for forms, manuals or work related papers.

Overall size: 12" W, 7" H, 5" D.



Door Kits and Hooks

PDK1 Door Kit for Full-Size vans converts M-Series fixed center panel into hinged door with keyed slam latch.

TA1 Hook Bar maximizes vertical storage space. 2" x 12" bar mounts to partition or other vertical surfaces. Four welded hooks with 2" hanger opening.

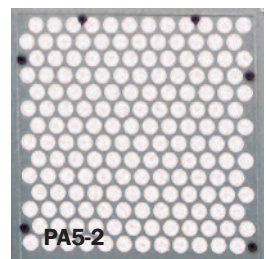

Plexiglass Cover Panels

PA5-1 fits S series full size van panels. 1 per kit.

PA5-2 fits M series full size van panels. 1 per kit.

PA5-6 fits C2 Ford full size van partition and wing panels only.

ACCESSORIES



ADseries Shelf Unit ADseries shelves are available in 3 widths and can be easily added and adjusted on the ADseries Rail System. See chart on pg.4.



DDF12 Driver Data File
Perfect for organizing files, manuals, invoices and more. Mounts between front seats. 12" W, 18" H, 22" D
Fits Full-Size Vans



DDF7 Driver Data File
Perfect for organizing files, manuals, invoices and more. Mounts between front seats. 7" W, 18" H, 22" D
Fits All Full-Size, and Mini Vans

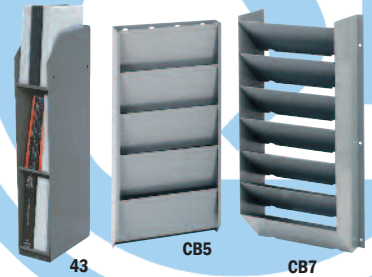

43 Three Shelf Catalog File
Overall size: 6" W, 34" H, 12" D.
CB5 Five Slot Literature Holder
Overall size: 12" W, 24" H, 2-1/2" D.
CB7 Seven Slot Literature Holder
Overall size: 14-3/4" W, 28-7/8" H, 7"D.



Door Storage Trays offer convenient access to parts and tools. Trays are available in four styles for mounting to doors, end panels, partitions or other vertical surfaces.

Model	Description
DST21	Door Storage Tray 20" W, 8" H, 4" D



Aerosol Can Tray secure cans for easy access on doors.

Model	Description
ACT3	3 Can Tray 11-3/4" W, 6-3/4" H, 4" D
ACT4	4 Can Tray 15-7/16" W, 6-3/4" H, 4" D



Hooks for cords, belts, or just about anything you need easy access to. Designed to mount to shelf ends, partition or other vertical surfaces.

Model	Description
UH10	1" hook
UH25	2-1/2" hook
UH50	5" hook
BRK14EPS	End Panel Bracket

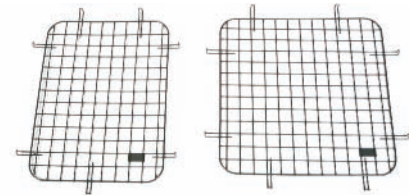

Wire Window Screens add security to cargo area windows. Rear quarter panel windows in full-size short and long wheelbase vans require multiple screen combinations. See chart.

Ford Full-Size 92-on	Model
Side curb sliding door	60-14
Side curb hinged door	60-15 & 60-16
Rear hinged door	60-17 & 60-18

Transit Connect	Model
Side sliding door	60-92 & 60-93
Rear hinged door	60-90 & 60-91



Welded Tank Racks secure refrigerant tanks for safe transport

Model	Description
WTR130250	(1) 30 lb & (2) 50 lb tanks
WTR230150	(2) 30 lb & (1) 50 lb tanks
WTR330	(3) 30 lb tanks
WTR350	(3) 50 lb tanks
WTR430	(4) 30 lb tanks



17A Six Shelf Catalog File is designed to store a variety of materials between the 3" shelf spacings.
Overall size: 11" W, 24" H, 12" D.



CB2 Two Book File is 6-1/4" wide with hinged retaining strap. Holds folders 12"H x 10-1/2"D.
Overall size: 6"W, 14"H, 12"D.

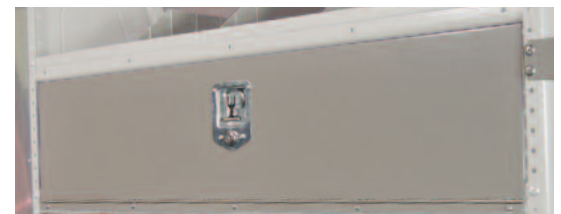

Locking Door Kits for ADseries shelving is available in 8" and 10" heights. Simply bolt on to transform a shelf into a locking cabinet. See chart on pg. 4.

E-SERIES VOCATIONAL PACKAGES



Alarm Package

Full-Size Long Wheelbase Vans

Ford package 2253F

Item	Model	Description	Qty.
1	33	KD Shelf Rack	1
2	1	Adjustable Shelf Cabinet	1
3	12	Open Side Shelf Cabinet	1
4	D6	Drawer Component 6"	3
5	43	Catalog File	1
6	4442	Welded Shelf Rack	1
7	DV14	14" Dividers	8
8	DK544	Door Kit	2
9	TA1	Hook Bar	2
10	2	Four Drawer Medium	1
11	9	Four Drawer Shallow	1
12	19	Two Drawer Medium	1
13	HD-42FP	Closed End Adjustable KD Shelving Over all size: 46"H, 42"W, 14"D	1
14	S1M2C2	FSV Partition & Wing Kit	1
15	DV44U4	Dividers	1

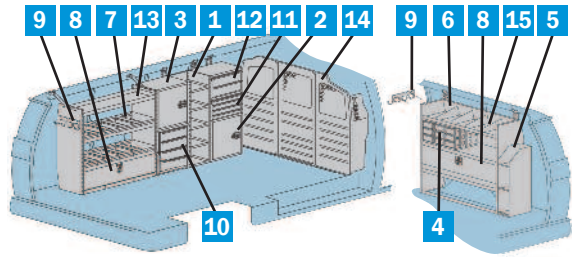

Locksmith Package

Full-Size Long Wheelbase Vans

Ford package 2255F

Item	Model	Description	Qty.
1	17A	Catalog File	1
2	MD506	Drawer Cabinet Module	1
3	MD608	Workbench Module (includes: 2-#54, #40, 2-#9, 2-#19, #14, KMB36)	1
4	TA1	Hook Bar	1
5	S1M2C2	FSV Partition & Wing Kit	1

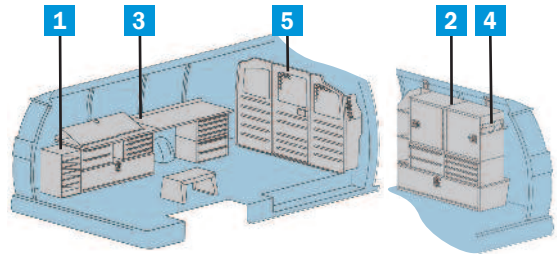

Cable TV Package

Full-Size Long Wheelbase Vans

Ford package 2258F

Item	Model	Description	Qty.
1	1	Adjustable Shelf Cabinet	2
2	DS36012H	Nine Drawer System	1
3	PA9	First Aid Tray	1
4	4442	Welded Shelf Rack	1
5	PA8	Fire Extinguisher	1
6	PA7	Reflector Flare Kit	1
7	TA2	Hard Hat Holder	1
8	50-42	KD Shelf Rack	1
9	TA1	Hook Bar	2
10	9	Four Drawer Shallow	1
11	19	Two Drawer Medium	2
12	DDF12	Data File (not shown)	1
13	KDRH2	Cable Reel Holder	1
14	S1M2C2	FSV Partition & Wing Kit	1
15	DV44U4	Dividers	1

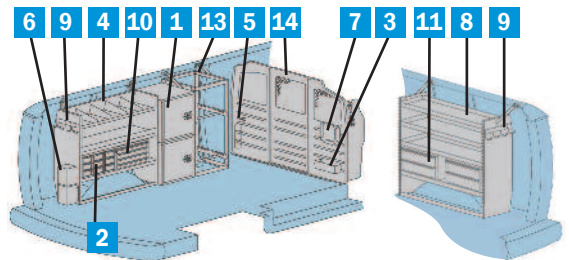

Cable TV Package

Full-Size Long Wheelbase Vans

Ford package 3230F

Item	Model	Description	Qty.
1	CL1446R	Cabinet Locker Tall-Door	1
2	MD507	Drawer Rack Module	1
3	TA1	Hook Bar	1
4	WRH5	5-Bar Wire Reel Holder	1
5	4442	Welded Shelf Rack	1
6	50-32	KD Shelf Rack	1
7	S1M2HC2	FSV Partition & Wing Kit	1
8	36	18-Drawer Unit	1
9	39	Riser	1
10	DV44U4	Dividers	1

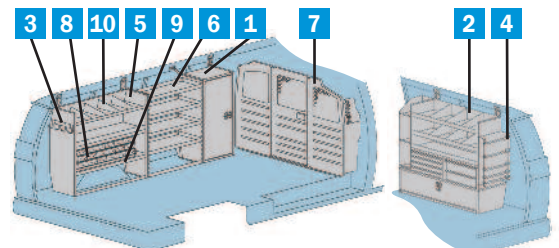

E-SERIES VOCATIONAL PACKAGES

Auto Glass Interior Package

Full-Size Long Wheelbase Vans

Ford package 4145F

Item	Model	Description	Qty.
1	AGR5H6L	Auto Glass Rack	1
2	AGSS24	Auto Glass Storage Station	1
3	28	Plastic Bins	5
4	AGSCH2	Suction Cup Holder	1
5	X1FSV	X1 Partition with Wing Kit	1
6	AGTW4	Auto Glass Trim Weld Storage	1

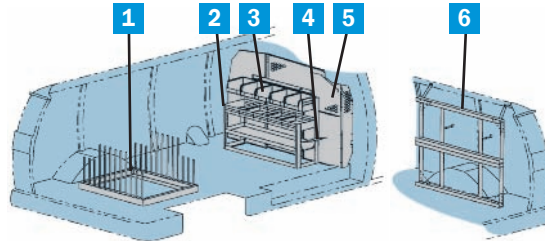

Ford Econoline Poly Liner Kit

Protect your Ford Econoline with this new Poly Liner Kit from Adrian Steel!

- Fit and finish of Adrian Steel's Poly Liner is superior to other van liners.
- Poly Liner protects valuable cargo during transportation. Cargo vans equipped with Adrian Steel's liner protects the interior appearance of the van itself.
- Molded liner conforms to the shape of the van walls.
- Seamless one piece street and curbside panels provide a clean fit and finish. The rear corners of the van have their own corner panels. Pre-cut holes for the jack.
- Compatible with Adrian Steel shelving.
- Side and rear door panels currently not available.
- Liners designed to work with OEM or after market floor mat.
- Liner Kit Package includes wall liner panels, headliner, E-track and straps.
- Available for long and extended long wheelbase Ford Econoline full size vans.

Note: Vehicles with rear air will require major modifications to accommodate liner.



Ford Poly Liner Kit

Model	Description
FDRWLN1	Ford RWB
FDXWLN1	Ford XWB



Poly Liner Kits are also available for the Transit Connect!

See page 11.

TRANSIT CONNECT PARTITIONS

TRANSIT CONNECT PARTITIONS ARE DESIGNED TO BE STONG AND LIGHTWEIGHT.

Five styles are available for your particular business needs. Perfect for mounting accessories and safety equipment for easy access.



P2TCFW Full Wire Mesh Partition

- Provides maximum visibility while safeguarding your van cab area against moving, shifting cargo.
- Recessed design allows for maximum adjustability of your driver and passenger seats.
- Lightweight and economical, without sacrificing safety and security.
- Partition weight: 19 lbs.



P2TCW Wire Mesh Partition

- Provides maximum visibility while safeguarding your van cab area against moving, shifting cargo.
- Recessed design allows for maximum adjustability of front seats.
- Steel header and full perimeter wings provide optimal security and prevents access to the cargo doors from the cab area or vice versa.
- Partition weight: 40 lbs.



Note: WKTC wing kit required and sold separately.



P2TCS Steel Partition

- Features all steel panels to safeguard the cab area against moving or shifting cargo.
- Recessed design allows for maximum adjustability of front seats.
- Perforated window provides full visibility of your cargo area and rear windows.
- Steel header and full perimeter wings provide optimal security.
- Partition weight: 55 lbs.



Best for noise reduction and climate control.

Best for noise reduction and climate control.

Note: WKTC wing kit required and sold separately.

P2TCH Hybrid Partition

- Features a honeycomb panel that provides strength and light weight design to safeguard the cab area against moving or shifting cargo.
- Recessed design allows for maximum adjustability of front seats.
- Perforated window provides full visibility of your cargo area and rear windows.
- Steel header and full perimeter wings provide optimal security.
- Partition weight: 50 lbs.



Note: WKTC wing kit required and sold separately.

TWO-POSITION PARTITION FOR TRANSIT CONNECT WAGONS OFFERS EVEN MORE OPTIONS.

This perforated partition can be used behind the rear Transit Connect seats, or can be slid forward with the seats folded up, gaining 20" of additional cargo space.



P22PTC Two-Position Partition

- Features strong steel construction and is the most flexible partition available.
- Designed to work with the fold up rear seats of the Transit Connect.
- When additional cargo room is needed, the P22PTC's flexibility makes moving to the forward position easy.
- To move the partition forward, move the rear seats into the folded position. Then, simply loosen the two hand knobs at either side of the partition, and with help from the heavy duty ball bearing slides, easily slide the partition forward into position and retighten the hand knobs.
- Features a wire mesh top that allows for maximum visibility.

TRANSIT CONNECT PACKAGES



4522 POLY LINER PACKAGE

Minimize the damage to your Transit Connect with the Poly Liner Package. The liner is molded to conform to the shape of the Transit's walls, and runs from floor to the headliner for a neat installation. E-track and straps are included for securing large cargo. The liner is designed to work with the OEM floor mat and a plywood floor. Easily add accessories including trade specific solutions, ladder racks, window screens, and more through your local Adrian Steel distributor.

The Poly Liner Package includes two poly wall panels, two full length E-tracks and two straps. Partition not included. Choose from steel, wire or hybrid partitions.



4529 INTERMEDIATE PACKAGE

The intermediate package features one AD32TC shelving unit (32"W x 46"H x 14"D) with three truly adjustable shelves. Shelves can be adjusted to your specific cargo needs in less than a minute. The precision stamped end panels and shelves provide lightweight, rugged and dependable storage. The intermediate interior provides 9.33 square feet of shelf space. One floor rail and one belt line rail is provided on the opposite side to secure cargo with two adjustable tie down hooks. Straps not included. Easily add essential accessories listed or choose additional accessories including trade specific solutions, ladder racks, window screens, and more.

Package weight: 61 lbs.



4530 FULL PACKAGE

The full package features two AD32TC steel shelving units (32"W x 46"H x 14"D) each with three truly adjustable shelves. Shelves can be adjusted to your specific cargo needs in less than a minute. The precision stamped end panels and shelves provide lightweight, rugged and dependable storage. The full interior provides 18.66 square feet of shelving space. Easily add essential accessories or choose additional accessories including trade specific solutions, ladder racks, window screens, and more.

Package weight: 113 lbs.



4531 PREMIUM PACKAGE

The premium package features two AD32TC steel shelving units (32"W x 46"H x 14"D) with three truly adjustable shelves. Shelves can be adjusted to your specific cargo needs in less than a minute. The precision stamped end panels and shelves provide lightweight, rugged and dependable storage. Package includes one #919 combination three drawer unit and one DC12 three drawer unit. Also includes one TA1 four hook bar mounted on the curbside rear panel that is perfect for extension cords and hoses. Easily add essential accessories listed or choose additional accessories including trade specific solutions, ladder racks, window screens, and more.

Package weight: 156 lbs.

TRANSIT CONNECT VOCATIONAL PACKAGES

4508 Plumbing Package

This package features lots of drawers for small parts storage, open shelving and a locking door kit to enclose a shelf for secure storage. Blue bins keep small parts organized and are removable to take to the jobsite. Includes Steel partition kit. Package weight: 345 lbs.

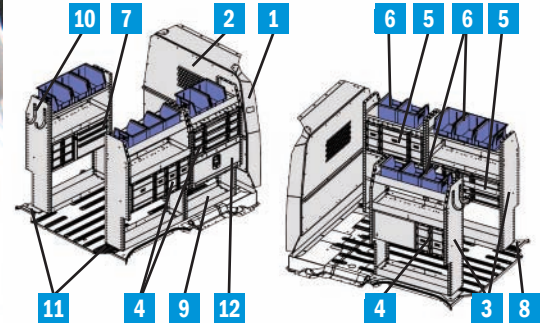

Item	Model	Description	Qty.
1	WKTC	Partition Wing Kit	1
2	P2TCS	Steel Partition Panel Kit	1
3	HD32TC	32" Shelf Unit, TC	2
4	DC6	Drawer Component 6"	7
5	DC12	Drawer Component 12"	2
6	28	Plastic Blue Bin	8
7	919	3 Drawer Combo	1
8	RK67TC	Rail Kit 67", TC	1
9	HD26TC	26" Shelf Unit, TC	1
10	UH50	5" Hook	2
11	FPKTC	Floor Plate Kit	2
12	DK26TC	Door Kit 8"x24"	1

4509 General Service Package

This package features drawers for small parts storage, divided shelving for organizing and a locking door kit to enclose a shelf for secure storage. Blue bins keep small parts organized and are removable to take to the jobsite. Includes Steel partition kit. Package weight: 370 lbs.

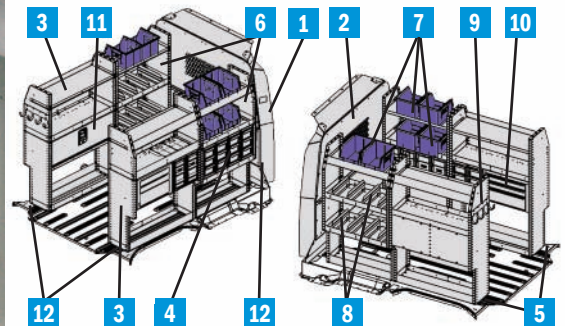

Item	Model	Description	Qty.
1	WKTC	Partition Wing Kit	1
2	P2TCS	Steel Partition Panel Kit	1
3	HD32TC	32" Shelf Unit, TC	2
4	DC6	Drawer Component 6"	6
5	RK67TC	Rail Kit 67", TC	2
6	HD26TC	26" Shelf Unit, TC	2
7	28	Plastic Blue Bin	6
8	DV12	Divider	8
9	TA1	Four Hook Bar	1
10	919	3 Drawer Combo	1
11	DK32TC	Door Kit 10"x30"	1
12	FPKTC	Floor Plate Kit	2

TRANSIT CONNECT VOCATIONAL PACKAGES

4510 Telecommunications Package

This package features lots of drawers for small parts storage, divided shelving, locking door kits for security and removable blue bins. A reel holder and hooks round out this specialty package. Includes Steel partition kit. Package weight: 310 lbs.

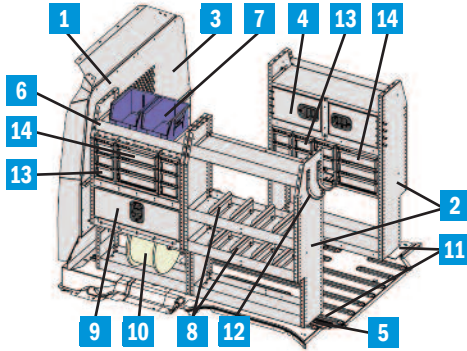

Item	Model	Description	Qty.
1	WKTC	Partition Wing Kit	1
2	HD32TC	32" Shelf Unit, TC	2
3	P2TCS	Steel Partition Panel Kit	1
4	CK3208	Cab Door Kit	1
5	RK67TC	Rail Kit 67", TC	1
6	HD26TC	26" Shelf Unit, TC	1
7	28	Plastic Blue Bin	2
8	DV12	Divider	8
9	DK26TC	Door Kit 8"x24"	1
10	KDRH1226	KD Reel Holder	1
11	FPKTC	Floor Plate Kit	2
12	UH50	5" Hook	2
13	DC6	Drawer Component 6"	5
14	DC12	Drawer Component 12"	2



4511 HVAC Package #1

This HVAC package features ample open shelving for large parts and tools, and divided shelving for organizing a variety of cargo. A tank rack accommodates 3-30lb. tanks and drawer units organize small fittings and connectors. Includes Steel partition kit. Package weight: 295 lbs.

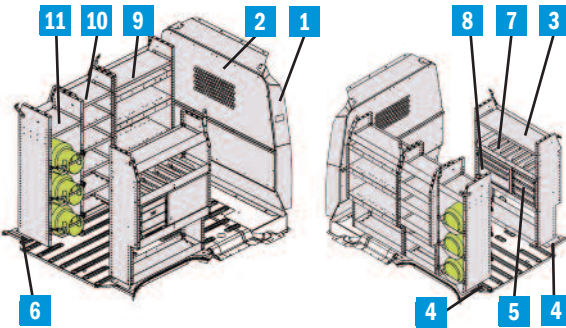

Item	Model	Description	Qty.
1	WKTC	Partition Wing Kit	1
2	P2TCS	Steel Partition Panel Kit	1
3	HD32TC	32" Shelf Unit, TC	1
4	FPKTC	Floor Plate Kit	2
5	DC12	Drawer Component 12"	1
6	RK67TC	Rail Kit 67", TC	1
7	DV12	Divider	4
8	919	Three Drawer Combo	1
9	HD26TC	26" Shelf Unit, TC	1
10	HD17TC	17" Shelf Unit, TC	1
11	TS3T1S	Tank Rack 3-30lb.	1



TRANSIT CONNECT VOCATIONAL PACKAGES

4512 Electrical Package

This package is designed to transport a variety of cargo in the Transit Connect. Open and divided shelves keep items organized and the blue bins allow for contents to be carried directly to the jobsite. Locking door kits and drawer units round out this versatile package. Includes Steel partition kit. Package weight: 280 lbs.

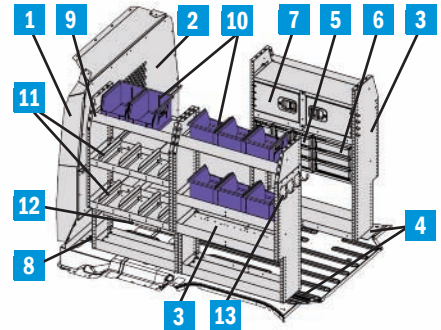

Item	Model	Description	Qty.
1	WKTC	Partition Wing Kit	1
2	P2TCS	Steel Partition Panel Kit	1
3	HD32TC	32" Shelf Unit, TC	2
4	FPKTC	Floor Plate Kit	2
5	DC6	Drawer Component 6"	3
6	DC12	Drawer Component 12"	1
7	CK3208	Cab Door Kit	1
8	RK67TC	Rail Kit 67", TC	1
9	HD26TC	26" Shelf Unit, TC	1
10	28	Plastic Blue Bin	8
11	DV12	Divider	8
12	KDRH1226	KD Reel Holder	1
13	TA1	Four Hook Bar	1

4513 Locksmith Package

This package for the Transit Connect features a 42" workbench with plenty of drawers for small parts storage. A locking Cab Door Kit encloses a shelf for secure storage. Includes Steel partition kit. Package weight: 220 lbs.

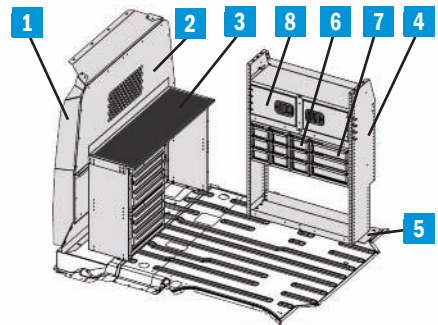

Item	Model	Description	Qty.
1	WKTC	Partition Wing Kit	1
2	P2TCS	Steel Partition Panel Kit	1
3	MD611	Workbench Module	1
4	HD32TC	32" Shelf Unit, TC	1
5	FPKTC	Floor Plate Kit	1
6	DC6	Drawer Component 6"	3
7	DC12	Drawer Component 12"	1
8	CK3208	Cab Door Kit	1

TRANSIT CONNECT VOCATIONAL PACKAGES

4517 Commercial Shelving Package

This package for the Transit Connect features two 32" shelving units with open and divided shelves. Versatility for changing needs and varying cargo. Includes Steel partition kit. Package weight: 180 lbs.

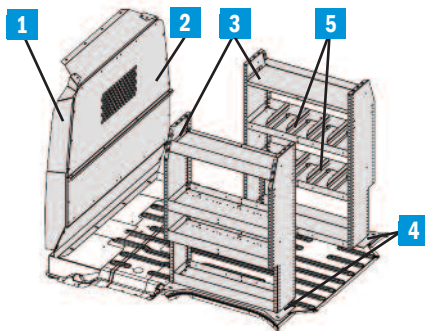

Item	Model	Description	Qty.
1	WKTC	Partition Wing Kit	1
2	P2TCS	Steel Partition Panel Kit	1
3	HD32TC	32" Shelf Unit, TC	2
4	FPKTC	Floor Plate Kit	2
5	DV12	Divider	8



4496 HVAC Package #2

This HVAC package features ample open shelving for large parts and tools. Adjustable shelving lines both sides and partition to maximize storage. The tank rack accommodates four 30lb. tanks. Includes Steel partition kit. Package weight: 360 lbs.

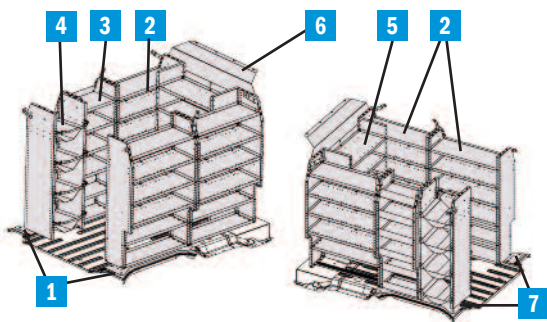

Item	Model	Description	Qty.
1	RK67TC	Rail Kit 67" TC	2
2	HD30TC	30" Shelf Unit, TC	3
3	HD17TC	17" Shelf Unit, TC	1
4	TS4T	Tank Rack 4-30lb.	1
5	HD27BTC	27" KD Shelf with back	1
6	HPTC4496	Partition Header Kit	1
7	FPKTC	Floor Plate Kit	2



TRANSIT CONNECT LADDER RACKS

GRIP YOUR LADDERS SECURELY WITH ADRIAN'S LOCKING STYLE LADDER RACKS.

Grip-Lock racks protect the sides and roof of your van during loading and unloading ladders. All Grip-Lock racks feature a lockable, gripping mechanism which firmly secures two ladders to the top of the van. Racks easily adjust for ladders of different sizes. The Transit Connect Grip-Lock features a no drill installation, composite extrusions on front and rear crossbows and uprights to protect ladders, and an all aluminum design for lasting quality within arms reach! The 63-TC shown below weighs under 40 lbs. to maximize the 150 lb. payload of the roof of the Transit Connect.

63-TC Double Lock Down

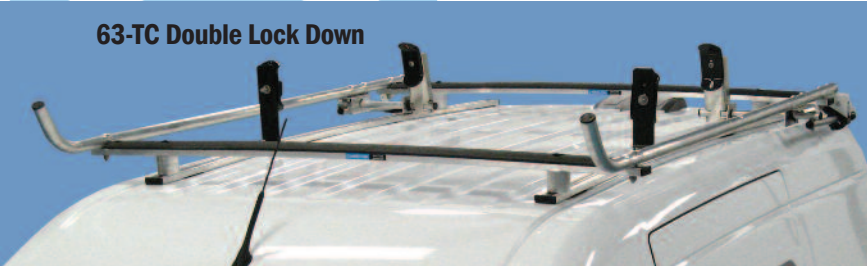

Transit Connect Grip-Lock Ladder Racks

Grip-Lock Ladder Racks	Model	Weight
SERIES 61 Single Lock-Down-curb-side	61-TC	30 lbs.
SERIES 63 Double Lock-Down	63-TC	40 lbs.
Third Bar Step Ladder Kit	1BTCGL	6 lbs.
Double Lock Down Conversion Kit for 61-TC	61TCSSGL	10 lbs.
Utility Rack Conversion Kit for 61-TC	61TCSSUR	5 lbs.

Features & Benefits

- Heavy-Duty actuating arm firmly grip ladder rungs to prevent shifting of ladder on rack.
- Gripping mechanism is lockable.
- Composite extrusions on front and rear crossbows and uprights protect ladders.
- Rung grips easily adjust to accommodate different types of ladders.
- All aluminum design.
- Mounts to pre-existing holes in roof. No drilling required.

Note: Due to the weight capacity of the roof of the Transit Connect, the LoadsRite, Grip-Lock and Utility racks for the Transit Connect have a 150 lb. weight capacity.

Note: Grip Lock and Utility racks for Transit Connect will accommodate up to a 24 ft. extension ladder.



MAKE YOUR TRANSIT CONNECT EVEN MORE VERSATILE WITH ADRIAN STEEL UTILITY RACKS.

The most flexible rack in the market, the 2BTC features an all aluminum design that allows you to maximize the 150 lb. payload of the roof of the Transit Connect. No drill installation and an innovative rail system allows the user to easily reposition the crossbows where they are needed. The 2BTC shown below weighs 20 lbs.

Transit Connect Utility Racks

Aluminum Utility Rack	Model	Weight
Two Bar Utility Rack, Aluminum Finish	2BTC	20 lbs.
Center Bar, Aluminum Finish	1BTC	6 lbs.

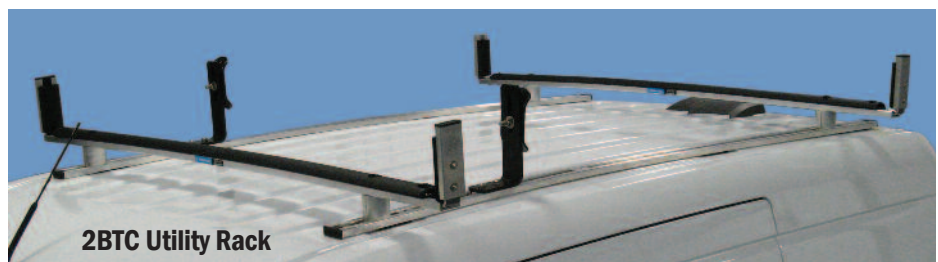

2BTC Utility Rack

TRANSIT CONNECT LADDER RACKS

STORE A 6 FOOT LADDER INSIDE YOUR TRANSIT CONNECT EQUIPPED WITH A PARTITION WITH TRANSIT CONNECT STEP LADDER PANELS.

This simple, yet effective solution replaces the existing rear door panels with panels that allow for the ends of the ladder to nest in the rear doors while protecting the wiring and locking mechanisms of those doors. The SLPTC Step Ladder Panels for Transit Connect are a safe, easy and economical way to fit a six foot step ladder inside a Transit Connect with a partition. The concave shape of the SLPTC panels allows the feet of the step ladder to extend into the rear doors. Another innovative product design from Adrian Steel!



SLPTC Features & Benefits

- Keep ladders inside and out of the elements.
- Does not add height to the vehicle, limiting access to parking structures.
- Replaces existing rear door panels
- Concave shape allows ladder feet to rest inside door.
- Protects door wiring and locking mechanisms.

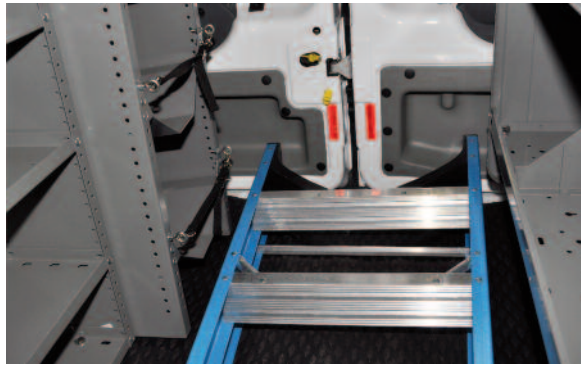

THE CONVENIENCE OF THE LOADSRITE LADDER RACK FOR YOUR TRANSIT CONNECT!

Adrian's LoadsRite Ladder Racks easily raise and lower to eliminate the need to climb, stretch or reach for your ladder. The unique design of the LoadsRite presents the ladder in a diagonal position bringing it to a comfortable working height...the right way to load and unload ladders.

LoadsRite Features & Benefits

- Aluminum bed frame, cast aluminum grab handle, stainless steel latch and all stainless steel fasteners.
- Allows side and rear door access while in the up or down position.
- Ladders can be padlocked for security.
- Hydraulic speed damper gently lowers ladder bed.
- Steel-Cote™ diamond-hard powder coat finish-for quality.
- Easy operation from the side of the vehicle.
- There are no straps to deal with, clamping of ladder is automatic.
- Rear bed lowers to present ladder at a convenient position.

Transit Connect LoadsRite Ladder Racks

LoadsRite Ladder Racks	Model	Weight
Single LoadsRite Ladder Rack - curbside only	LR6100TCC	76 lbs.
Combo LoadsRite Ladder Rack	LR6400TCC	88 lbs.
Single LoadsRite Add-On Kit for Grip-Lock Ladder Racks	LR61GPTC	12 lbs.

Note: Due to the weight capacity of the roof of the Transit Connect, the LoadsRite, Grip-Lock and Utility racks for the Transit Connect have a 150 lb. weight capacity.

Note: Grip Lock and Utility racks for Transit Connect will accommodate up to a 24 ft. extension ladder

LR6100TCC with optional LR61GPTC shown



E-SERIES LADDER RACKS

LOADING LADDERS JUST GOT DOWN RIGHT EASY.

Adrian's LoadsRite Ladder Racks easily raise and lower to eliminate the need to climb, stretch or reach for your ladder on top or your van. The unique design of the LoadsRite presents the ladder in a diagonal position bringing it to a comfortable working height in the right way. LoadsRite, the right way to load and unload ladders.



Description	Model	Support Front to back	Spacing Side to side
Full-Size Ford Vans			
Single LoadsRite Ladder Rack	LR6100-WCF or WSF*	84"	70"
Single LoadsRite Add-On Kit for Grip-Lock Racks	LR6200-WCF or WSF*	84"	70"
Double LoadsRite Ladder Rack	LR6300-WF	84"	70"
Combo LoadsRite Ladder Rack	LR6400-WCF or WSF*	84"	70"
10'-12' Step Ladder Kit	29691-0	N/A	N/A

*Note: LoadsRite is ordered preconfigured for the streetside or curbside

GRIP YOUR LADDERS SECURELY WITH ADRIAN'S LOCKING STYLE LADDER RACKS.

Protect the sides and roof of your van during loading and unloading ladders. Grip-Lock racks feature a lockable, gripping mechanism which firmly secures one or two ladders to the top of the van. Racks easily adjust for ladders of different sizes. Galvanneal plated steel.



Full-Size Ford Vans	Model	Support Front-back	Spacing Side-side
SERIES 61 Single Lock-Down	61-1	84"	71"
SERIES 63 Double Lock-Down	63-1	84"	71"
SERIES 64 COMBO Double Lock-Down	64-1	108"	71"

2B UTILITY RACKS ARE LOADED WITH FEATURES

Carry ladders, scaffolding, plank, pipe and more! The 2B Utility racks are available in both aluminum and steel and feature an extra wide mount foot, welded tie hooks, durable black or white powder coat finish and require no drilling or cutting to install.

Product	Model	Description
Aluminum/Full-Size Van		
One Bar/ Aluminum	1BAR-B	Mid Cross Beam Assembly/Black
One Bar/ Aluminum	1BAR-W	Mid Cross Beam Assembly/White
Two Bar/ Aluminum	2BAR-B	Black
Two Bar/ Aluminum	2BAR-W	White
Side Stop Kit	SSK-BA	Black
Side Stop Kit	SSK-WA	White

Steel/ Full-Size Van	Model	Description
One Bar/ Steel	1BRS-B	Mid Cross Beam Assembly/Black
One Bar/ Steel	1BRS-W	Mid Cross Beam Assembly/White
Two Bar/ Steel	2BRS-B	Black
Two Bar/ Steel	2BRS-W	White
Side Stop Kit	SSK-BS	Black
Side Stop Kit	SSK-WS	White



STORE LADDERS INSIDE YOUR ECONOLINE WITH THE LADDER KEEPER.

Designed to be loaded from outside the vehicle, the Ladder Keeper features a spring-loaded clamp that holds the ladder securely in place. Just set the top of the ladder in the front clamp bracket and push it forward until the bottom of the ladder sits in the rear clamp bracket. Can be mounted to the ceiling or wall of the vehicle and includes all parts needed to carry up to a 8' ladder. An extension kit is available for longer ladders.

Ladder Keeper includes all parts needed to carry up to a 6' ladder in a regular wheelbase van and an 8' ladder in a long wheelbase van. To accommodate larger vehicles or ladders, you will require the LKX extension that provides 4' of additional track.

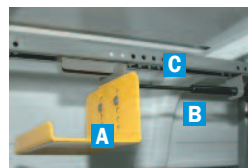

- A** Plastic coated clamps protect ladder rungs.
- B** Gas spring compresses ladder for quiet and secure transportation.
- C** Extruded track makes loading and unloading simple.

F-SERIES COMMERCIAL PICKUP EQUIPMENT

Crossbox

AD100 Single Lid 12.5" Deep
AD200 Double Lid 12.5" Deep

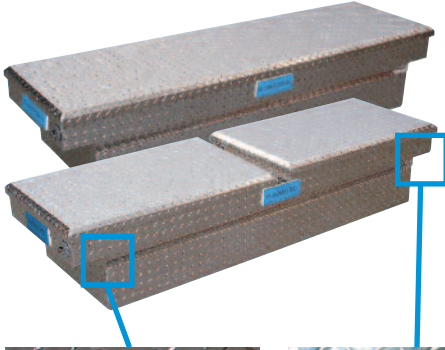

Crossbox

AD201 Double Lid 17.5" Deep
AD101 Single Lid 17.5" Deep

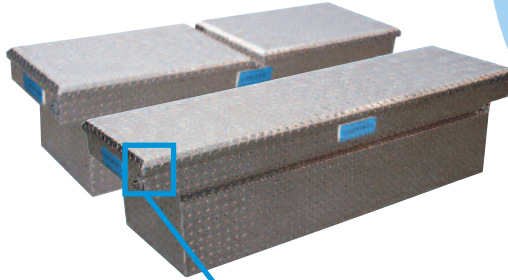

Sidebox

AD302 64" Side Box
AD303 46" Side Box

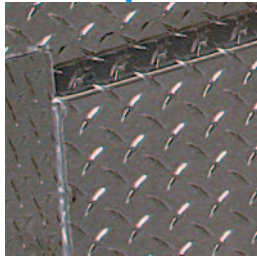
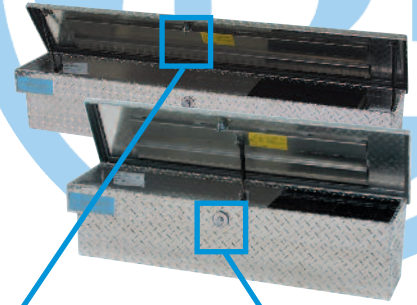

Fully welded construction Designed for strength and leak prevention.



No-drill brackets Secure the box to your truck without drilling while protecting your truck bed rails.



Rigid low profile dome lid Provides maximum visibility out your rear window.

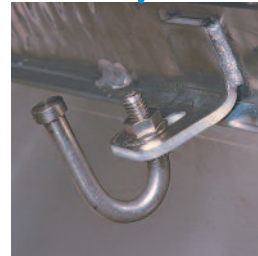

Security Fully adjustable intrusion resistant striker keeps contents more secure.



Push button locks Automotive push button lock with double bitting lock cylinder make opening easy.

Full-Size Pickup Load Runner

2" high strength round tubing
51" width inside to inside of truss tubes
2" square crossbars

Mid-Size Pickup Load Runner

1.75" high strength round tubing
48.5" width inside to inside of truss tubes
1.75" square crossbars

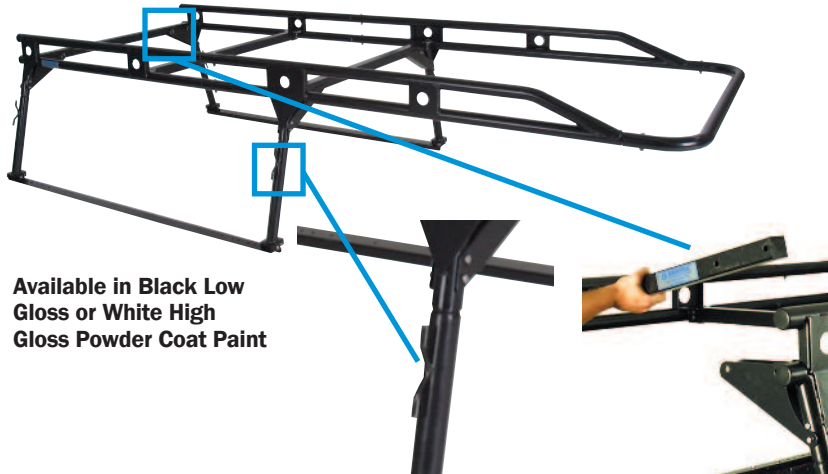

Available in Black Low Gloss or White High Gloss Powder Coat Paint

Welded Tie-Down Cleats

Removable Center and Rear Crossbar

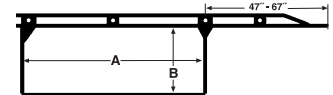

How to order tool box envelope

Rack dimensions for A (inside length) and B (inside height) are contained in the Load Runner rack fit Chart. Dimensions show available area for mounting cross and side boxes. Side rail height is 8" above cross supports. Cab over extension is 47" for regular cab models and 67" for extended cab models.

Note: Exterior ladder rack and accessory equipment can cause increased cab area noise on vans and pickups.

Load Runner rack fit

Please state make, model, year and length of pickup bed when ordering.

	Black	White	Model	A-Dim	B-Dim
Ford RD	SLR-8FR	SLR-8FRW	8'	91 1/2"	25"
Ford RD	SLR-8FE	SLR-8FEW	8'	91 1/2"	25"
Ford Super Duty	SLR-8FRS	SLR-8FRSW	8'	91 1/2"	29"
Full-Size/Regular Cab	SLR-6FRS	SLR-6FRSW	6'	71 1/2"	29"
Ford Super Duty	SLR-8FES	SLR-8FESW	8'	91 1/2"	29"
Full-Size/Extended Cab	SLR-6FES	SLR-6FESW	6'	71 1/2"	29"
Ford Ranger Regular Cab	MSLR-6FRFB	MSLR-6FRFW	6'	68 3/8"	22 7/8"
Ford Ranger ExtendedCab	MSLR-6FEFB	MSLR-6FEFW	6'	68 3/8"	22 7/8"

Note: Wind deflector included with extended cab Load Runner pickup racks.
Note: Not designed to fit sportside or flareside bed models.

ADRIAN STEEL COMPANY

QUALITY

- Adrian Steel is proud to be the first and only van equipment manufacturer to obtain TS16949 certification.
- Our products are durable and reliable. Warranty claims are less than 1% of sales.
- Our warranty covers our products for three years or 36,000 miles.

INNOVATIVE PRODUCTS WITH FEATURES THAT MATTER

- Drawers that stay closed while in transit.
- ADseries truly adjustable shelving.
- LoadsRite and Grip-Lock ladder racks that load and unload the safe and right way.
- Interior ladder storage.
- Plug and Play accessories.
- Anti-slam drawer latches, and much more!



COMMITMENT

- At Adrian Steel, we are committed to you beyond the upfit!
 - A dedicated Customer Care Team at corporate headquarters.
 - A network of highly qualified distributors to support you locally.
 - Our commitment to provide the best cargo management solutions in North America.

EXPERIENCE

- Over One Million vans upfitted, and counting! It's a fact that an organized vehicle increases work flow efficiencies and reduces inventory damages.
- Recognized as a National Truck Equipment Association MVP.

SERVICE

- Adrian Steel Products can be purchased throughout North America at authorized Adrian Steel distributors.
- Adrian Steel Customer Service Representatives are available M-F, 8am - 5pm EST at **1-800-677-2726**.
- E-mail us at info@adriansteel.com with questions, comments and feedback.
- Visit AdrianSteel.com for the most up-to-date product information, distributor locator, product catalogs, videos and more.

**FIND THE SOLUTIONS YOU NEED AT YOUR ADRIAN STEEL DISTRIBUTOR,
IN OUR CATALOGS AND ON-LINE AT ADRIANSTEEL.COM.**



CARGO VAN



PICKUP TRUCK



SPRINTER VAN



WALK-IN VAN



CARGO TRAILER

Distributed by



ADRIAN STEEL®

Cargo Management Solutions for Commercial Vehicles

906 James Street, Adrian, Michigan 49221-3996
517-265-6194 Fax: 517-265-5834
Toll Free 800-677-2726
adriansteel.com info@adriansteel.com